

1. Supply main panel (PLC) and control panel (HMI) with power and connect Ethernet cable from main panel to control panel. Ethernet should be in its own conduit. Shielded cable is recommended but not normally required. Supply voltage to the main panel is 120Vac with a 480Vac transformer available upon request. Note: **The communication cable must be terminated in accordance with TIA/EIA-568 A or B** or crosstalk will develop and communication will fail. For advanced control / connections, consult the user manual.

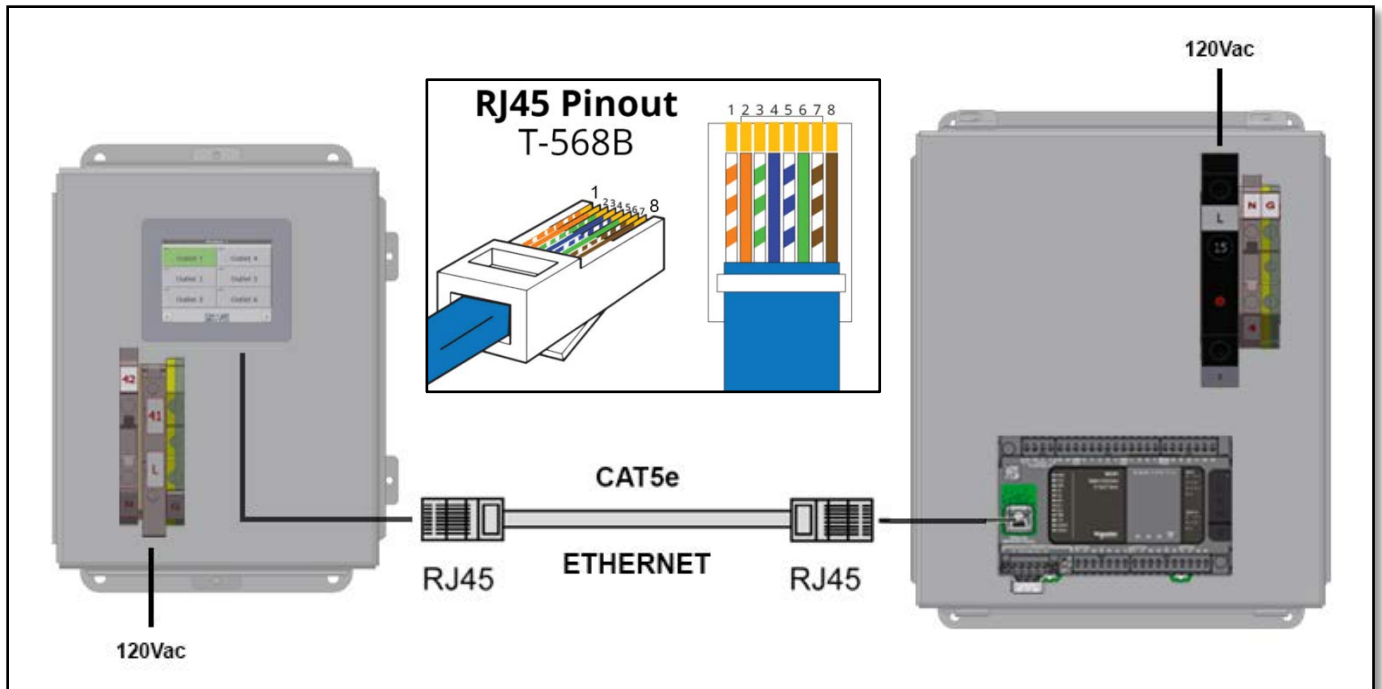

2. The machine will boot to “MACHINE STOP” mode and will not automate until the “RESET” button is pressed. Touch the banner at the top of the screen to bring up the messages dialog which contains the “RESET” button. Press the “X” in the top right corner to close the message dialog box.



3. To change outlets, touch the button on the “Home” screen to see the “Outlet Selection” screen. To change the outlet, touch and **long hold** for 1 second or more to activate.



NOTE: Touch the “CMF” logo at any time to return to the “Home” screen. When the “Home” screen is visible, touch the “CMF” logo to display the “Menu” screen where you can rename outlets and access other information.

Custom Metal Fabricators Inc.
3194 R Ave.
Herington, KS 67449
Phone: 785-258-3744

User Manual: www.cmfmfg.com